

# LABORHITS

## Vortexer LLG-uniTEXER

**NEW!**

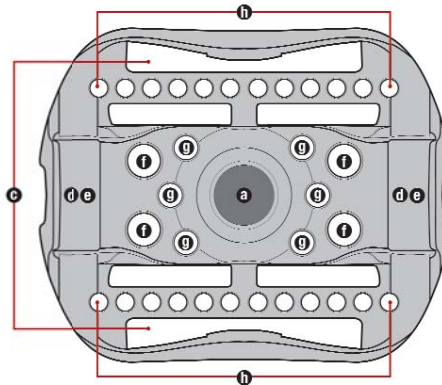

6 Different Sizes of Tubes Including standard assay plate	
Mixing head holding capacity	
a	Center pad area for hand held mixing Assay plate x 1 (to be used with retention cords)
c	50 ml conical tubes x 2 (horizontally mounted)
d	15 ml conical tubes x 2 (horizontally mounted)
e	5 ml tubes x 2 (horizontally mounted in the same retention space as 15 ml)
f	1.5/2 ml microfuge tubes x 4 (vertically mounted)
g	0.5 ml microfuge tubes x 6 (vertically mounted)
h	0.2 ml microfuge tubes (strip tubes) x 24 (vertically mounted)



### Unique Vortexer with universal attachment

- Vortexer with single carrier head, accommodating the most popular consumables and tubes within the lab: for 1 x assay plate, 2 x 50ml conical tubes, 2 x 15ml conical tubes, 2 x 5ml conical tubes, 4 x 1.5/2ml microcentrifuge tubes, 6 x 0.5ml and 24 x 0.2ml microcentrifuge tubes
- Carrier head is very easy to clean
- Precise speed control via a variable rotary switch
- Elastomeric feet ensure excellent stability on the bench and quieter operation
- Modern design
- Robust, ABS housing

#### Specifications

Type of movement:	orbital/vortex
Orbital diameter:	3.7mm
Speed:	1000, 2000, 3000rpm
Dimensions (WxDxH):	173 x 198 x 198mm
Weight:	3.8kg
Protection class:	IP 20
Supply requirements:	220V, 50/60Hz
Guarantee:	3 years

Type	PK	Cat. No.
uniTEXER	1	6.261 826